

The level of the liquid present in a vessel is checked by one or more *displacers* (i.e. floats correctly ballasted) hung on a metallic rope. When level rises up to the preset height, the displacer makes the output device trip (*trip on rise*); when level comes down again and exceeds the preset point, the displacer makes the output device come back to the initial position (*rest on fall*); between the *trip* and *reset* points there is always a gap, named *differential* : see below. The inverse function is available too : *Trip on fall* and *Reset on rise*. The output device can be electric or pneumatic, is snap action and is placed in the housing. All of them are mounted on top vessel.

Several types of Switches are available, with some elements in common.

- Body and flange in the ratings ANSI 150, 300, 600psi, in carbon steel ASTM A106B (body) and ASTM 105N (flange), stainless AISI 304, or stainless AISI 316. Flange : ANSI or UNI/DIN standards (page 32-33).
- Displacer and rope (L=1÷10m) in stainless AISI 316. The displacer can be fixed on the rope at the desired height, decided by the user himself.
- For liquids with specific gravity from 500kg/m³ up.
 - Housing and housing-holder : as described below and on page 34.
 - Outer finish : green, for marine and tropical climates, as on page 34.

The Switches meet the PED and ATEX standard (page 37).

DF1 – It is provided with 1 displacer and 1 output, electric or pneumatic.

- The output trips when liquid rises (or falls) up to displacer and resets when falls (or rises) of 65 ±15mm (differential not changeable).
 - Output : - electric (1 or 2 microswitches SPDT with simultaneous action : see page 11; within Ø155×200mm housing);
 - pneumatic (1 valve ON-OFF, in Ø125×180mm housing).
- Use : Alarm for Max or Min level, control of loading pump, etc.

DF2A – It is provided with 2 displacers and 1 output, electric or pneumatic.

- The output trips when liquid rises up to the displacer A, and resets when falls up to the displacer B (or on the contrary).
- The differential can be decided by the same installer : he will fix the displacer A at the trip height, and B at the reset height; in this way the gap between the two displacers corresponds to the wished differential. The minimum differential is 160mm, with the 2 blocks placed under B.
- Output : - electric (1 or 2 micros SPDT with simultaneous action : page 11; in Ø155×200mm housing);
- pneumatic (1 valve ON-OFF, in Ø125×180mm housing).
- Use : Loading of vessel, to stop a loading pump when level rises up to the displacer A, and to start it again when level falls to the displacer B.

DF2B – It is provided with 2 displacers and 2 electric outputs.

- The output 1 is activated by displacer A placed at L₁, while the output 2 is activated by displacer B placed at L₂. The two trips are independent and depend only on the heights at which the displacers are fixed. Each of them resets with differential of 65 ±15mm.
- DF2B operates as if it were composed by two DF1.
- Each output : 1 or 2 micros SPDT with simultaneous action : pag. 11; within Ø155×200mm housing.
- Use: Alarm for Max or Min level. It operates as composed by two DF1.

DF3 : They are provided with 3 displa. and various electric outputs (each output has 1 or 2 micros SPDT with simultaneous action : page 11) :

DF3A – The output 1 is activated by the displacer A placed at L₁ (can be used as Max level alarm); the output 2 is activated by the displacer B placed at L₂ (*trip*) and by the displacer C placed at L₃ (*reset*). It can be used to control the loading/unloading pump. In Ø155×200mm housing. It operates as if it were composed by one DF1 + one DF2A.

DF3B – The output 1 is activated by displacers A placed at L₁ (*trip*) and B placed at L₂ (*reset*), and can be used to load/unload a vessel. The out-put 2 is activated by displacer C placed at L₃, and can be used as Min level alarm. In Ø155×200mm housing. It operates as if it were composed by a DF2A + a DF1.

DF3C – It is provided with 3 displacers and 3 independent electric outputs. Within Ø155×250mm housing. It operates as if it were composed by three DF1

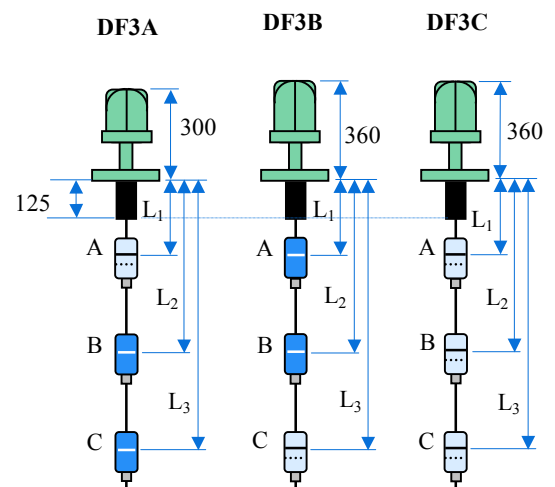
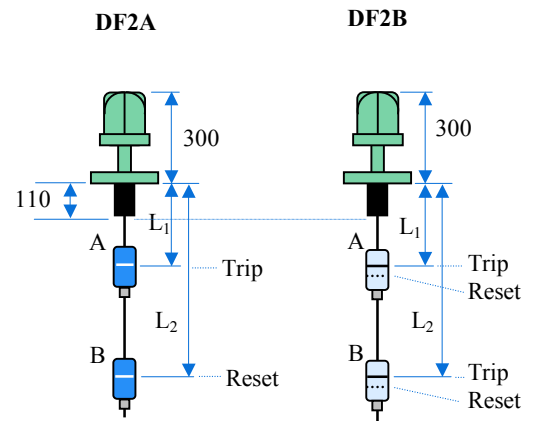
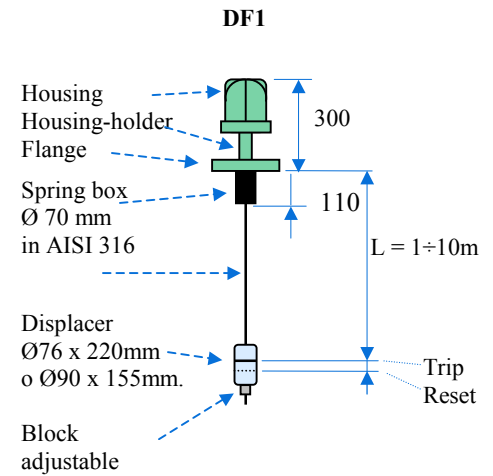

Upon request, special versions can be produced too : page 12.

CONNECTIONS to vessel of DF :

By means of :

- F** Flange ANSI with RF face
- J** " " RJ (Ring Joint)

Rating :

- 15** ANSI 150 psi
- 30** ANSI 300
- 60** ANSI 600

Diameter :

- G** Ø 3" [with displacer Ø76×220mm]
- H** Ø 4" [with displacer Ø90×155mm] ⁽¹⁾

BODY and CONNECTION in :

- AC** Carbon steel ⁽¹⁾
- A4** Stainless steel AISI 304
- A6** " " AISI 316

Flanges are available in UNI/DIN too : page 33.
Upon request, body can be in Hastelloy, Teflon, PVC,

HOUSING (page 34-35) :

Electric or pneumatic output :

Number of electric outputs : 1, 2, 3, etc microswitches SPDT, according to the Switch type

- A••** Microswitch, dust-proof, 6A – 24Vdc, silver contact ⁽¹⁾ ⁽²⁾
- B••** " " " 6A res – 5A ind – 30Vdc, silver contact ⁽³⁾
- Q••** " " " 1mA–5Vdc(min value), 1A–125Vac(max), gold contact ⁽⁴⁾
- R••** " " sealed in inert gas, 3A res–1,5A ind–30Vdc, silver contact ⁽⁵⁾
- Z••** " " " 1mA–5Vdc(min), 0,5A–30Vdc(max), gold contact ⁽⁶⁾
- 1 PA•** 1 Pneumatic valve ON-OFF : opens air when level rises, with 2 manometers ⁽¹⁾
- 1 PC•** " " " closes " " " " " "

Hole for electric connection :

- A•** Threaded ½" NPT-F for cable-gland (not supplied)
- B•** " " ¾" NPT-F, " " (not supplied) ⁽¹⁾

- 3 ways : On/Off/Vent
- Usage pressures : 1÷5,5Bar / 15÷80psi
- PA↔PC : page 34.

Housing-holder :

- S** For standard temperatures, –20/+180°C
- H** For high temperatures, +181/+450°C, with fins
- L** For low temperatures, –21/–60°C, without fins

On the following page some special versions of DF are shown.

ROPE for trip at L (total) :

1	1m	2	2m	3	3m	4	4m	5	5m
6	6m	7	7m	8	8m	9	9m	D	10m

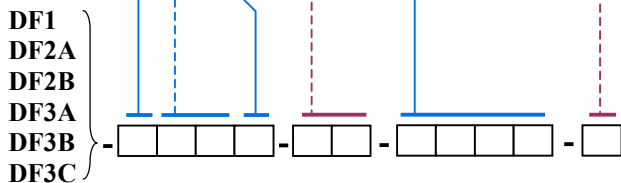

Short description

In addition to the above Short description, *Domizi Snc* need also the following information, absolutely necessary.

Fluid : upper : Specific gravity of fluid : upper : kg/m³
 " lower : " " " " lower : kg/m³
 Temperature : Minimum °C Operating °C Maximum °C
 Pressure : Minimum bar (*) Operating bar (*) Maximum bar (*)
 Instrument function : Other :

(*) Simplify : 15bar ~ 15atm ~ 15kg/cm² ~ 15KPa ~ 1,5Mpa

⁽¹⁾ – It is the standard option.
⁽²⁾ – Micro A : also 6A resistive – 250Vac; temperatures of : –25/+85°C.
⁽³⁾ – Micro B : also 15A resistive – 3A inductive – 250Vac; temperatures of : –25/+80°C.
⁽⁴⁾ – Micro Q : also 1A – 125Vac, but is recommended for very low electric loads (e.g. insulating barriers with few mA and V); temperatures of : –55/+85°C.
⁽⁵⁾ – Micro R : also 1A resistive – 0,8A inductive – 220Vac; temperatures of : –55/+150°C.
⁽⁶⁾ – Micro Z : recommended for very low electric loads (e.g. insulating barriers with few mA and V); temperatures of : –55/+150°C.

LEVEL SWITCHES Type DF in some special versions

For particular applications *Domizi Snc* can produce **DF** Switches in special versions too; here are some of possible versions.

DF1 for *floating cover*, in TG version

When switches are mounted on vessels in which the liquid is protected by a *floating cover*, displacer is replaced by a solid body with similar weight as displacer's.

When body is lifted by floating cover, it makes output device trip; the output device can be electric or pneumatic, and is placed within housing.

APPLICATIONS. Trip for *High or Low level*, with the same performances as DF1 type.

Other information is on the following page.

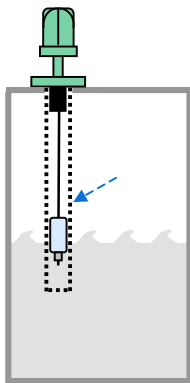
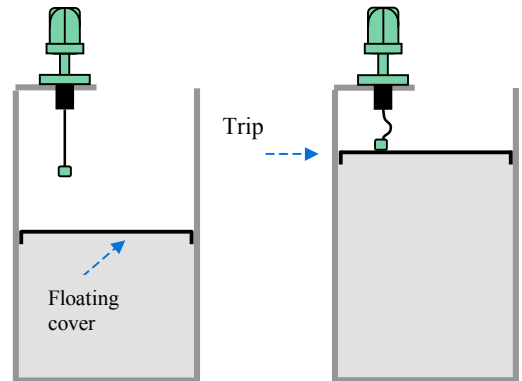

DF1, DF2A-DF2B, DF3A-DF3B-DF3C with *damping tube*, in TC version

When switches are mounted on vessels containing *turbulent* liquids, *Domizi Snc* recommend to protect displacers within a *damping tube*, to avoid untimely trips.

Usually such a tube is procured and mounted by the same vessel installer, or, upon request, can be supplied by *Domizi Snc* already assembled on the Switch.

APPLICATIONS. Trip for *High or Low level*, *pump On/Off turning*, as for all the DF types. Other information is on the following page.

DF1, DF2A-DF2B, DF3A-DF3B-DF3C in DB version

When a Switch is mounted on a side of vessels and shall carry out performances being impossible with DB Switch (e.g. *pump On-Off turning with very wide differentials*), *Domizi Snc* propose to use a DF Switch included within a DB body. In this way you get an instrument with performances being typical of DF and with mechanical look of DB, both as body and as connection/inspection flanges.

APPLICATIONS. Trip of *High or Low level*, *pump On/Off turning*, as for all the DF types. Other information is on the following page.

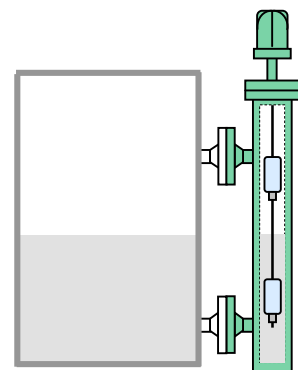

VERSION of DF :

- TG** Switch for floating cover
- TC** Switch with damping tube
- DB** Switch DF in the body of DB : see herein after

CONNECTION to vessel of DF in TG, TC version :

- By means of:
- F** Flange ANSI with face RF
 - J** " ANSI " RJ (Ring Joint)
- Rating :
- 15** ANSI 150 psi
 - 30** ANSI 300
 - 60** ANSI 600
- Diameter :
- G** Ø 3"
 - H** Ø 4" (1)

BODY and CONNECTIONS in :

- AC** Carbon steel (1)
- A4** Stainless steel AISI 304
- A6** " " AISI 316

Flanges are available in UNI/DIN too : page 33.
Upon request, body can be in Hastelloy, Teflon, PVC, etc.

HOUSING (page 34-35) :

Recommended when DF is included in DB body.

Electric or pneumatic outputs :

Number of electric outputs : 1, 2, 3, etc microswitch SPDT, according to the Switch type

- A** Microswitch, dust-proof, 6A – 24Vdc, silver contact (1) (2)
- B** " " " 6A res – 5A ind – 30Vdc, silver contact (3)
- Q** " " " 1mA–5Vdc(valore min), 1A–125Vac(max), gold contact (4)
- R** " " " sealed in inert gas, 3A res–1,5A ind–30Vdc, silver contact (5)
- Z** " " " 1mA–5Vdc(min), 0,5A–30Vdc(max), gold contact (6)
- 1 PA** 1 Pneumatic valve ON-OFF : opens air when level rises, with 2 manometers (1)
- 1 PC** " " " closes " " " " " " " "

Hole for electric connection :

- A** Threaded 1/2" NPT-F for cable-gland (not supplied)
- B** " 3/4" NPT-F, " " " (not supplied) (1)

• 3 ways : On/Off/Vent
• Usage pressures : 1÷5,5Bar / 15÷80psi
• PA↔PC : page 34.

Housing-holder :

- S** For standard temperatures, –20/+180°C
- H** For high temperatures, +181/+450°C, with fins
- L** For low temperatures, –21/–60°C, without fins

ROPE for trip at L (total) :

- | | | | | |
|-------------|-------------|-------------|-------------|--------------|
| 1 1m | 2 2m | 3 3m | 4 4m | 5 5m |
| 6 6m | 7 7m | 8 8m | 9 9m | D 10m |

If Switch DF is included in DB body, add :

- F** Flanges RF
- J** Flanges RJ
- N** Sleeves NPT-F
- P** Slee. NPT-M
- S** Socket welding slee.

- LL** Mounting *Side-Side*
- LF** Mounting *Side-Bottom*

Connection flanges diameter :	Connection sleeves diam. :
1" 1 1/2" 2"	1" 1 1/2" 2"
C D E	C D E

M Center-to-center distance between connections (mm).

Options on bottom body (drain) :

- NN** *Side-Bottom* mounting : no accessory is possible.
- A** *Side-Side* mounting : with hole, threa. 1/2" NPT-F
- B** " " " " " 3/4" NPT-F (1)
- N** " " " " " no accessory
- T** " " " " " with plug
- R** " " " " " with valve
- S** " " " " " with valve+plug

- DF1**
- DF2A**
- DF2B**
- DF3A**
- DF3B**
- DF3C**

Short description



Leave blank, if not closed in DB

In addition to the above Short description, *Domizi Snc* need also the following information, absolutely necessary.

Fluid : upper : Specific gravity of fluid : upper : kg/m³
 " lower : " " " lower : kg/m³
 Temperature : Minimum °C Operating °C Maximum °C
 Pressure : Minimum bar (*) Operating bar (*) Maximum bar (*)
 Instrument function : Other :

(*) Simplify : 15bar ~ 15atm ~ 15kg/cm² ~ 15KPa ~ 1,5Mpa

(1) – It is the standard option.
 (2) – Micro A : also 6A resistive – 250Vac; temperatures of : –25/+85°C.
 (3) – Micro B : also 15A resistive – 3A inductive – 250Vac; temperatures of : –25/+80°C.
 (4) – Micro Q : also 1A – 125Vac, but is recommended for very low electric loads (e.g. insulating barriers with few mA and V); temperatures of : –55/+85°C.
 (5) – Micro R : also 1A resistive – 0,8A inductive – 220Vac; temperatures of : –55/+150°C.
 (6) – Micro Z : recommended for very low electric loads (e.g. insulating barriers with few mA and V); temperatures of : –55/+150°C.